



V-INFINITY
a division of CUI INC

date 11/2009

page 1 of 4

SERIES: 12 W WALL PLUG

DESCRIPTION: SWITCHING POWER SUPPLY

FEATURES

- universal AC input
- regulated output voltage
- short circuit, over load protection
- meets EISA / efficiency level IV regulations
- custom designs available



MODEL	output voltage		output current		output wattage	ripple*	efficiency level	cord length (mm)
	nominal (V dc)		min (A)	max (A)	max (W)	max. (mVp-p)		
EPS050250UPS-P5P-KH	5		0	2.5	12.5	80	IV	1800 ±30
EPS060175UPS-P5P-KH	6		0	1.75	10.5	80	IV	1800 ±30
EPS090120UPS-P5P-KH	9		0	1.2	10.8	90	IV	1800 ±30
EPS120100UPS-P5P-KH	12		0	1.0	12	120	IV	1800 ±30
EPS150080UPS-P5P-KH	15		0	0.8	12	150	IV	1800 ±30
EPS180067UPS-P5P-KH	18		0	0.67	12.1	180	V	1800 ±30
EPS240050UPS-P5P-KH	24		0	0.5	12	240	IV	1800 ±30

*full load, 100~240 Vac input, measured at 20MHz bandwidth with a 22 uF electrolytic cap and a 0.1 uF ceramic cap on the output

**SERIES: 12 W WALL PLUG****DESCRIPTION: SWITCHING POWER SUPPLY****INPUT**

parameter	conditions/description	min	nom	max	units
rated input voltage		100		240	V ac
input voltage range		90		264	V ac
rated frequency		50		60	Hz
frequency range		47		63	Hz
inrush current				50	A
no load power consumption	100 ~ 240 V ac input			0.5	W

OUTPUT

parameter	conditions/description	min	nom	max	units
line regulation			±2		%
load regulation			±5		%
temp. coefficient			0.05		%/°C
start-up time	at 110 V ac, full load			2	s
hold-up time	at 110 V ac, full load	10			ms
over voltage protection		125%		180%	V dc
overload protection	Overload results in decreased output voltage until auto-recovery once the over load is removed.				
short circuit protection	auto-recovery				

SAFETY & EMI

parameter	conditions/description	min	nom	max	units
HI-POT	input to output at 4 mA for 2 seconds input to case at 4 mA for 2 seconds			3000 3000	V ac V ac
insulation resistance	input to output at 500 V dc	50			MΩ
safety approvals	UL/cUL (60950-1)				
EMI standard	FCC part 15 class B				
RoHS compliant	yes				
LPS power supply	yes				

ENVIRONMENTAL

parameter	conditions/description	min	nom	max	units
operating temperature		0		40	°C
operating humidity		10		95	%
storage temperature		-20		70	°C
storage humidity		10		95	%

RELIABILITY

parameter	conditions/description	min	nom	max	units
MTBF	at 25°C	50,000			hours



V-INFINITY
a division of CUI INC

date 11/2009

page 3 of 4

SERIES: 12 W WALL PLUG

DESCRIPTION: SWITCHING POWER SUPPLY

MECHANICAL DRAWING

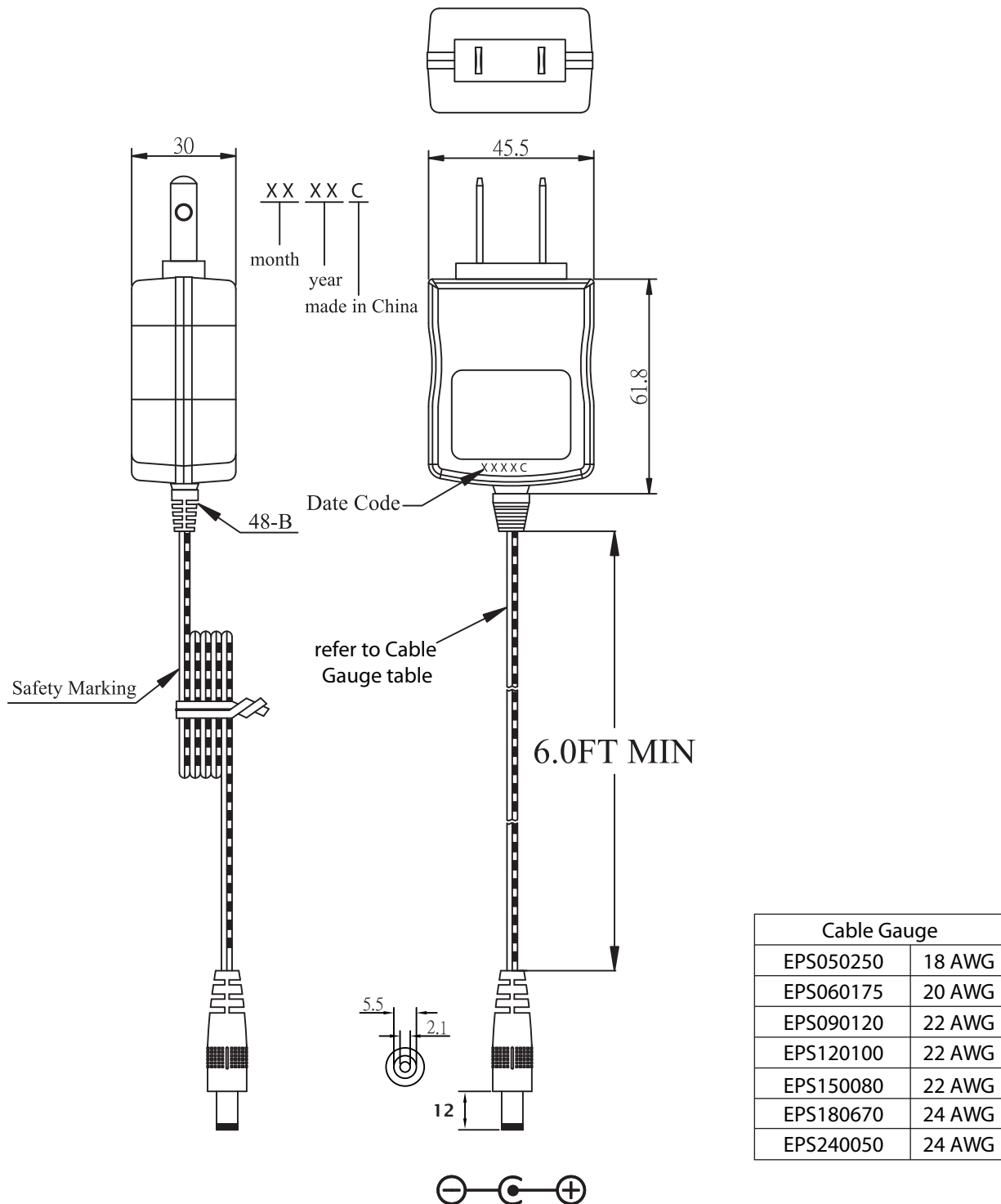



V-INFINITY
a division of CUI INC

date 11/2009

page 4 of 4

SERIES: 12 W WALL PLUG

DESCRIPTION: SWITCHING POWER SUPPLY

INDIVIDUAL PACKAGING

BOX

Length: 100

Width: 60

Height: 52

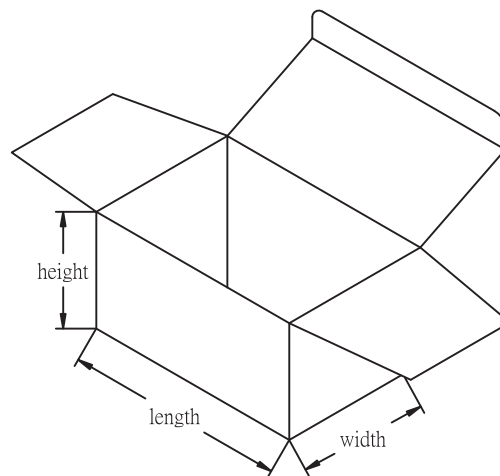

PACKAGING

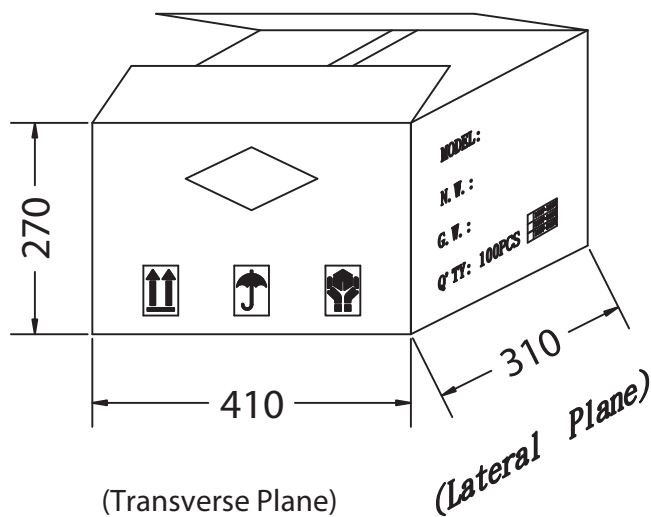

MODEL:	
N.W.:	
G.W.:	
Q'TY: 100PCS	

	100V~120V
	200V~240V
	100V~240V

