

**V-INFINITY**
a division of CUI INC

date 09/2010

page 1 of 6

SERIES: 15 W WALL PLUG**DESCRIPTION: SWITCHING POWER SUPPLY****FEATURES**

- universal AC input
- regulated output voltage
- short circuit
- meets EISA / efficiency level IV regulations
- custom designs available



MODEL	output voltage		output current		output wattage	ripple*	efficiency level	cord length (mm)
	nominal (V dc)		min (A)	max (A)	max (W)	max. (mVp-p)		
EPS050260UH	5		0	2.6	13	150	IV	1000 +150/-0
EPS060250UH	6		0	2.5	15	150	IV	1000 +150/-0
EPS070214UH	7.5		0	2.14	14.7	150	IV	1000 +150/-0
EPS090166UH	9		0	1.66	14.9	150	IV	1000 +150/-0
EPS120125UH	12		0	1.25	15	150	IV	1830 +150/-0
EPS150100UH	15		0	1.0	15	150	IV	1830 +150/-0
EPS180083UH	18		0	0.83	14.9	150	IV	1830 +150/-0
EPS200075UH	20		0	0.75	15	250	IV	1830 +150/-0
EPS240063UH	24		0	0.63	15.1	250	IV	1830 +150/-0

*at full load, 100 ~ 240 V ac input, measured at 20MHz bandwidth with a 10 uF electrolytic cap and a 0.1 uF ceramic cap on the output

PART NUMBER KEY**EPS050260UH - XX - SZ - CXX**Base Number
example of 5 V dc, 2.6 ADC Plug type:
see output plug options
on page 5Factory
DesignationReserved for
custom orders

**V-INFINITY**
a division of CUI INC

date 09/2010

page 2 of 6

SERIES: 15 W WALL PLUG**DESCRIPTION: SWITCHING POWER SUPPLY**

INPUT

parameter	conditions/description	min	nom	max	units
rated input voltage		100		240	V ac
input voltage range		90		264	V ac
rated frequency		50		60	Hz
frequency range		47		63	Hz
inrush current	at 115 V ac, cool start at 230 V ac, cool start			30 50	A A
no load power consumption	100 ~ 240 V ac input			0.3	W

OUTPUT

parameter	conditions/description	min	nom	max	units
line regulation			±1		%
load regulation			±5		%
over voltage protection	output shutdown	110%		140%	V dc
short circuit protection	output shut down and auto restart				

SAFETY & EMI

parameter	conditions/description	min	nom	max	units
HI-POT	input to output at 10 mA for 1 minute			3000	V ac
insulation resistance	input to output at 500 V dc	100			MΩ
safety approvals	UL/cUL (60950-1)				
EMI standard	FCC part 15 class B				
leakage current				0.25	mA
RoHS compliant	yes				

ENVIRONMENTAL

parameter	conditions/description	min	nom	max	units
operating temperature		0		40	°C
operating humidity		20		80	%
storage temperature		-10		70	°C
storage humidity		10		90	%



V-INFINITY
a division of CUI INC

date 09/2010

page 3 of 6

SERIES: 15 W WALL PLUG

DESCRIPTION: SWITCHING POWER SUPPLY

MECHANICAL DRAWING

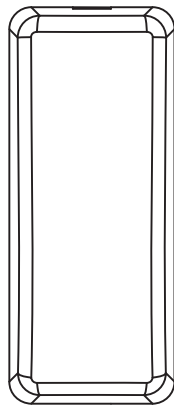

input plug	Fixed (UL)
weight	180 g
case size	72 L x 47.6 W x 35 H mm tolerance: ± 1 mm

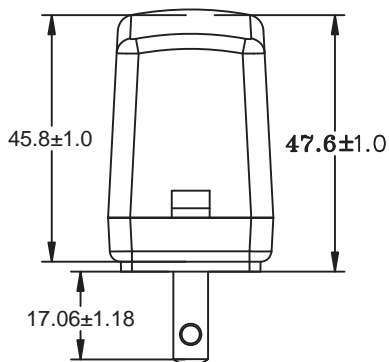
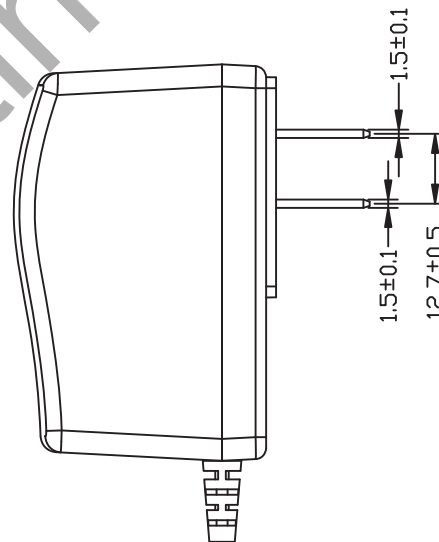
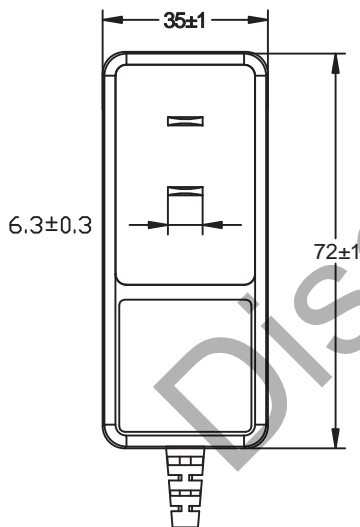

Discontinued



SERIES: 15 W WALL PLUG

DESCRIPTION: SWITCHING POWER SUPPLY

DC CORD

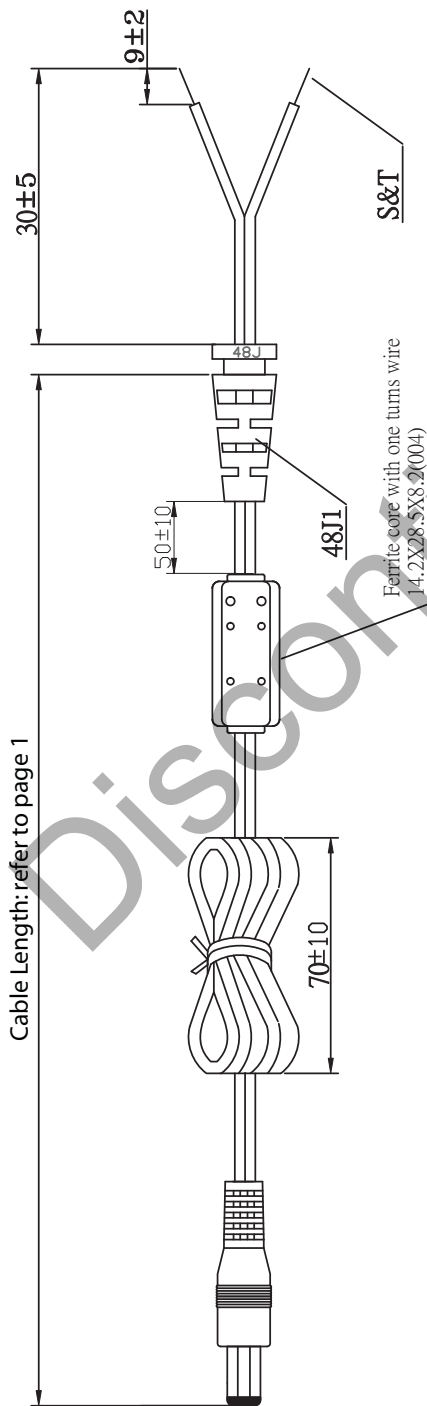

Black wire, white stripe: Positive

Cable Gauge	
EP5050260	18 AWG
EP5060250	18 AWG
EP5070214	18 AWG
EP5090166	20 AWG
EP5120125	20 AWG
EP5150100	20 AWG
EP5180083	20 AWG
EP5200075	20 AWG
EP5240063	20 AWG



SERIES: 15 W WALL PLUG

DESCRIPTION: SWITCHING POWER SUPPLY

DC OUTPUT PLUG OPTIONS

3.5 mm Phono Plug

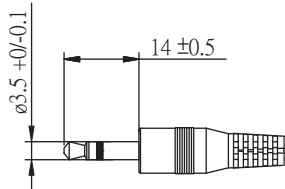

P1

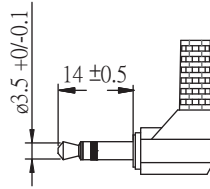

P1R

*Tip positive

Standard DC Plug

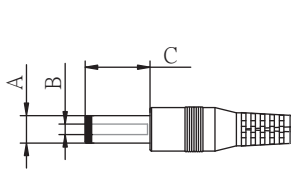

Standard PX

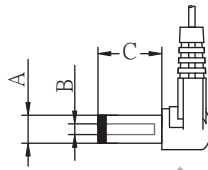

Right Angle PXR

	A	B	C	Unit
P5/P5R	5.5	2.1	12	mm
P6/P6R	5.5	2.5	9.5	mm
P7/P7R	3.5	1.3	9.5	mm
P8/P8R	3.8	1.35	9.5	mm
P9/P9R	3.8	1.05	9.5	mm

Locking DC Plug

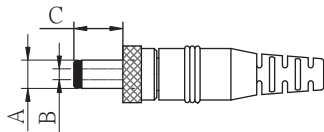

	A	B	C	Unit
P10	5.5	2.1	9.5	mm
P11	5.5	2.5	9.5	mm

EIAJ Plugs

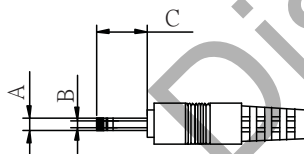

Standard PXX

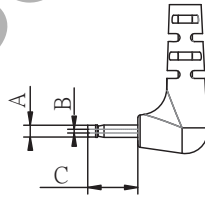

Right Angle PXXR

	EIAJ	A	B	C	D	Unit
P12/P12R	EIAJ-1	2.35	0.7	9.5	NA	mm
P13/P13R	EIAJ-2	4.0	1.7	9.5	5.0	mm
P14/P14R	EIAJ-3	4.75	1.7	9.5	5.0	mm

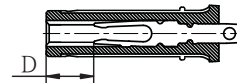

Stripped and Tinned

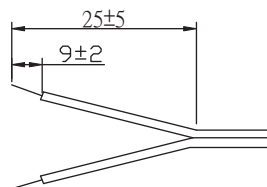

DC PLUG TYPE

ST
stripped and tinned

PXX X X

Plug type Plug angle: "blank" = standard
R = right angle Plug polarity: "blank" = N/A
P = center positive N = center negative

⊖ ⊕ ⊕ ⊖

*Contact CUI for additional output plug options.



V-INFINITY
a division of CUI INC

date 09/2010

page 6 of 6

SERIES: 15 W WALL PLUG

DESCRIPTION: SWITCHING POWER SUPPLY

INDIVIDUAL PACKAGING

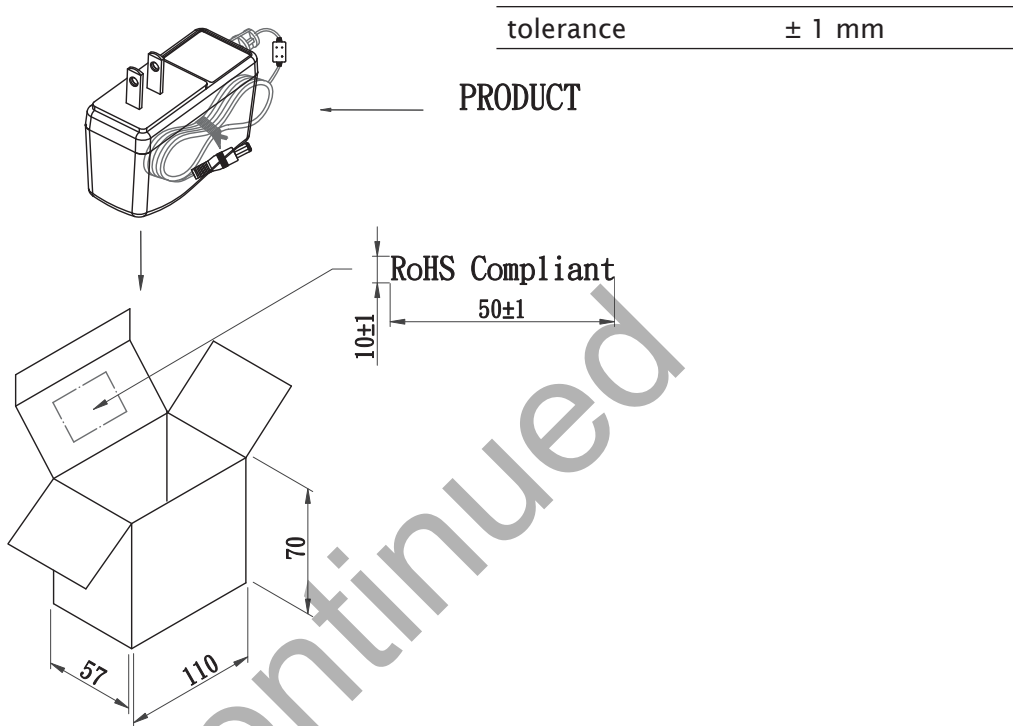

PACKAGING

tolerance	+7 / -0 mm
-----------	------------

CARTON INTERNAL SIZE: 450*308*300mm

Q'TY: 80PCS(20*4)

"RoHS Compliant"

