

SERIES: PSE-1800 | **DESCRIPTION:** AC-DC HOT-SWAP POWER SUPPLY

FEATURES

- up to 1800 W continuous power
- 1U package
- I²C communication for monitoring and control
- redundant (N+1) operation
- blind mate connections for hot-swap
- power factor correction
- 3.3 Vdc (0.5A) standby voltage
- DROOP current sharing
- single I/O connector for AC input, DC output & signals
- remote on/off control, power good signal



MODEL	output voltage	output current max	output power ^{1,2} max	ripple and noise max	efficiency ³ typ
	(Vdc)	(A)	(W)	(mVp-p)	(%)
PSE-1800-48	48	37.5	1800	480	85

Notes:

1. At 90~180 Vac input, maximum of 1000 W.
2. At 180~264 Vac input, maximum of 1800 W.
3. At 90 Vac input.

PART NUMBER KEY

PSE-1800 - 48 - CXX

Base Number

Output Voltage

Reserved for Custom Configurations

INPUT

parameter	conditions/description	min	typ	max	units
voltage		90		264	Vac
frequency		50		60	Hz
current	at 90 Vac, full load			11	A
inrush current	half cycle, cold start, 25°C at 115 Vac, 60 Hz at 230 Vac, 50 Hz			20 40	A A
leakage current				1.5	mArms
power factor correction		0.95	0.98		

OUTPUT - V1 (MAIN OUTPUT)

parameter	conditions/description	min	typ	max	units
regulation			±3		%
transient response	25% step load, recovery to 1% within 1 ms, slew rate 1 A/μs			3	%
hold-up time	at full load in redundant operation	12 20			ms ms

OUTPUT - V2 (STANDBY OUTPUT)

parameter	conditions/description	min	typ	max	units
output voltage			3.3		Vdc
output current		0		0.5	A
ripple and noise				50	mVp-p
regulation			±5		%

STATUS & CONTROL

parameter	conditions/description	min	typ	max	units
I ² C interface	SCL 1000 kHz clock rate SDA data line				
remote sense	main ooutput				
remote enable	"active low" enables main output, last-mate / first-break enable pin				
current share	droop share				
status	AC OK, DC OK and OTP_OK (open collector, active "low"=ok); and PS_Present				
LED indicator	AC OK & DC OK indicators				

PROTECTIONS

parameter	conditions/description	min	typ	max	units
over voltage protection	V1 V2	110		60 120	Vdc %
over current protection	followed by latching shutdown after 2 s			120	%
over temperature protection	output shut down, auto recovery				

SAFETY & COMPLIANCE

parameter	conditions/description	min	typ	max	units
safety approvals	cTUVus EN60950-1, CE (LVD)				
emissions	FCC 15 Sub Part J, Class A, EN55022 Class A, VCCI Class A				
harmonic compliance	EN61000-3-2 Class A				
surges (mains)	IEC/EN 61000-4-5				
voltage dips/interruptions	IEC/EN 61000-4-11				

SAFETY & COMPLIANCE (CONTINUED)

parameter	conditions/description	min	typ	max	units
MTBF	as per Telcordia SR332, 40°C, full load	500,000			hours
RoHS	2011/65/EU				

ENVIRONMENTAL

parameter	conditions/description	min	typ	max	units
operating temperature		0		55	°C
storage temperature		-40		85	°C

MECHANICAL

parameter	conditions/description	min	typ	max	units
dimensions	11.00 x 4.00 x 1.60 (279.4 x 101.6 x 40.6 mm)				inches
cooling / airflow	internal high performance 38 mm fan, air inlet at face; exhaust at connector				
input / output connector	FCI P/N 51939-531LF mates with FCI 51915-299LF				
hot-swap capability	fully hot-swappable, blind mate connector				

MECHANICAL DRAWING

units: inches [mm]
 tolerance:
 X.XX ±0.02 [0.50]
 X.XXX ±0.010 [0.25]

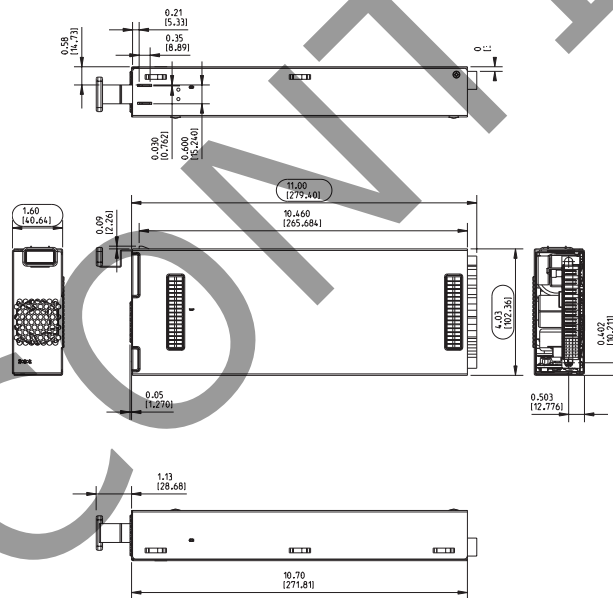
**INPUT / OUTPUT CONNECTOR**

Pins	Function	Pins	Function	Pins	Function	Pins	Function	Pins	Function
P1	No Blade	A1	+V Sense	B1	ISHARE	C1	-V Sense	D1	Reserved
P2	+48 V	A2	V Pgm	B2	I ² C Address A0	C2	I ² C Address A1	D2	I ² C Address A2
P3	+48 V	A3	Reserved	B3	Reserved	C3	Reserved	D3	Reserved
P4	No Blade	A4	AC_OK_L	B4	DC_OK_L	C4	PS_Present_L	D4	OTP_OK_L
P5	-48 V	A5	Signal Return	B5	I ² C SCL	C5	I ² C SDA	D5	+3.3 VSB
P6	-48 V	A6	-3.3 VSB	B6	Reserved	C6	Reserved	D6	Remote_On_L (short pin)
P7	Earth	--	--	--	--	--	--	--	--
P8	Neutral	--	--	--	--	--	--	--	--
P9	Line	--	--	--	--	--	--	--	--

REVISION HISTORY

rev.	description	date
1.0	initial release	05/07/2015

The revision history provided is for informational purposes only and is believed to be accurate.



CUI INC[®]

Headquarters
20050 SW 112th Ave.
Tualatin, OR 97062
800.275.4899

Fax 503.612.2383
cui.com
techsupport@cui.com

CUI offers a two (2) year limited warranty. Complete warranty information is listed on our website.

CUI reserves the right to make changes to the product at any time without notice. Information provided by CUI is believed to be accurate and reliable. However, no responsibility is assumed by CUI for its use, nor for any infringements of patents or other rights of third parties which may result from its use.

CUI products are not authorized or warranted for use as critical components in equipment that requires an extremely high level of reliability. A critical component is any component of a life support device or system whose failure to perform can be reasonably expected to cause the failure of the life support device or system, or to affect its safety or effectiveness.