

PART NUMBER: VDN1-DIP series**DESCRIPTION:** DC/DC converter**description**

Designed to convert fixed voltages into an isolated voltage, the VDN1-DIP series is well suited for providing board-mount local supplies in a wide range of applications, including mixed analog/digital circuits, test & measurement equip., process/machine controls, datacom/telecom fields, etc...

The semi-regulated output can be followed by 3-terminal regulators to provide output protection, in addition to output regulation.

features

- isolated 1 W output
- temperature range: -40°C~+85°C
- unregulated
- high efficiency to 80%
- dual independent voltage output
- small footprint
- DIP package style
- industry standard pinout
- UL94-V0 package
- no heatsink required
- 1K Vdc isolation
- power density 0.85 W/cm³
- no external component required
- low cost



model number	input voltage		output voltage	output current		package efficiency	style
	nominal	range		max.	min.		
VDN1-S5-DI5-DIP	5 Vdc	4.5~5.5 Vdc	5, 5 Vdc	100, 100 mA	10, 10 mA	72%	DIP
VDN1-S5-DI9-DIP	5 Vdc	4.5~5.5 Vdc	9, 9 Vdc	56, 56 mA	6, 6 mA	75%	DIP
VDN1-S5-DI12-DIP	5 Vdc	4.5~5.5 Vdc	12, 12 Vdc	42, 42 mA	5, 5 mA	78%	DIP
VDN1-S5-DI15-DIP	5 Vdc	4.5~5.5 Vdc	15, 15 Vdc	33, 33 mA	4, 4 mA	79%	DIP
VDN1-S12-DI5-DIP	12 Vdc	10.8~13.2 Vdc	5, 5 Vdc	100, 100 mA	10, 10 mA	74%	DIP
VDN1-S12-DI9-DIP	12 Vdc	10.8~13.2 Vdc	9, 9 Vdc	56, 56 mA	6, 6 mA	76%	DIP
VDN1-S12-DI12-DIP	12 Vdc	10.8~13.2 Vdc	12, 12 Vdc	42, 42 mA	5, 5 mA	79%	DIP
VDN1-S12-DI15-DIP	12 Vdc	10.8~13.2 Vdc	15, 15 Vdc	33, 33 mA	4, 4 mA	80%	DIP
VDN1-S15-DI5-DIP	15 Vdc	13.5~16.5 Vdc	5, 5 Vdc	100, 100 mA	10, 10 mA	74%	DIP
VDN1-S15-DI9-DIP	15 Vdc	13.5~16.5 Vdc	9, 9 Vdc	56, 56 mA	6, 6 mA	75%	DIP
VDN1-S15-DI12-DIP	15 Vdc	13.5~16.5 Vdc	12, 12 Vdc	42, 42 mA	5, 5 mA	79%	DIP
VDN1-S15-DI15-DIP	15 Vdc	13.5~16.5 Vdc	15, 15 Vdc	33, 33 mA	4, 4 mA	79%	DIP
VDN1-S24-DI5-DIP	24 Vdc	21.6~26.4 Vdc	5, 5 Vdc	100, 100 mA	10, 10 mA	74%	DIP
VDN1-S24-DI9-DIP	24 Vdc	21.6~26.4 Vdc	9, 9 Vdc	56, 56 mA	6, 6 mA	76%	DIP
VDN1-S24-DI12-DIP	24 Vdc	21.6~26.4 Vdc	12, 12 Vdc	42, 42 mA	5, 5 mA	80%	DIP
VDN1-S24-DI15-DIP	24 Vdc	21.6~26.4 Vdc	15, 15 Vdc	33, 33 mA	4, 4 mA	81%	DIP

PART NUMBER: VDN1-DIP series**DESCRIPTION:** DC/DC converter**OUTPUT SPECIFICATIONS**

item	test conditions	min.	typ.	max.	units
output power		0.1		1	W
line regulation	for Vin change of 1%			1.2	%
load regulation	10% to 100% full load			15	%
output voltage accuracy	see tolerance envelope graph				
temperature drift	@ 100% load			0.03	%/°C
output ripple	20 MHz bandwidth		50	75	mVp-p
switching frequency	full load, nominal input		100		KHz

GENERAL SPECIFICATIONS

short circuit protection	<1 second
temperature rise at full load	25°C Max, 15°C typ.
cooling	free air convection
operating temperature range	-40°C to +85°C
storage temperature range	-55°C to +125°C
soldering temperature	300°C (1.5mm from case for 10 sec.)
storage humidity range	<95%
case material	plastic (UL94-V0)
MTBF	>3,500,000 hrs.
burn-in	full load at +85°C, for 4 hours at no-load and 4 hours at full load.

ISOLATION SPECIFICATIONS

item	test conditions	min.	typ.	max	units
isolation voltage	tested for 1 min.	1000			Vdc
insulation resistance	test at 500 Vdc	1000			M Ω

NOTE:

- All specifications measured at TA=25°C, humidity <75%, nominal input voltage and rated output load unless otherwise specified.

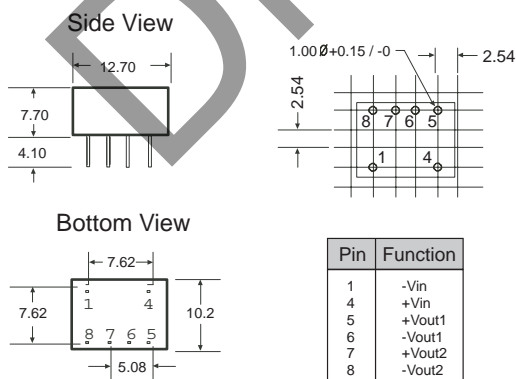
DIMENSIONS (mm)

Note: All Pins on a 2.54mm pitch; All Pin diameters are 0.50 mm; all dimensions in mm.

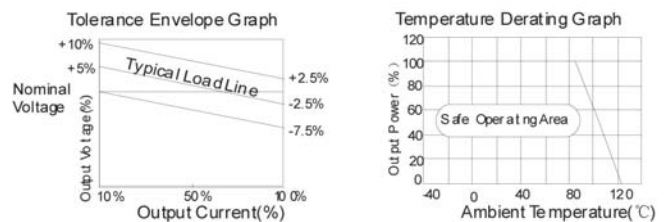
TYPICAL CHARACTERISTICS

PART NUMBER: VDN1-DIP series**DESCRIPTION:** DC/DC converter**APPLICATION NOTES:**

- Input filtering

To reduce the reflected ripple current and minimize EMI, especially when the converter input is more than 2" away from the DC source, it is recommended to connect a low ESR electrolytic capacitor between Vin and Gnd. The values suggested are as shown in Table 1. If additional filtering is required, the capacitance may be increased, or expanded to an LC network as shown in Figure 1.

TABLE 1

Input Voltage	External Input Capacitance
5 V	4.7 μ F
12 V	2.2 μ F
15 V	2.2 μ F
24 V	1.0 μ F

- Output filtering

An output capacitor is needed to meet output ripple requirements as shown in Table 2. Output capacitance may be increased for additional filtering, but should not exceed 10 μ F or expanded to an LC network as in Figure 1.

TABLE 2

Vout	External Output Capacitance
5 V	10 μ F
9 V	4.7 μ F
12 V	2.2 μ F
15 V	1 μ F
24 V	0.47 μ F

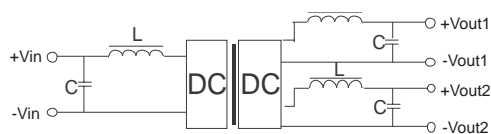

<Figure 1>

- Minimum loading

The converter needs a minimum of 10% loading to maintain output regulation. Operation under no-load conditions will not cause immediate damages but may reduce reliability, and cause performance not to meet specifications.

- Regulation

With a semi-regulated design, the converter's output voltage varies with load current and will change proportionally to the input voltage. If regulated output is needed, an external regulator can be used as shown in Figure 2.

- Protection

The converter has minimal protection against input over-voltage or output over-load, and may be permanently damaged if exposed to these conditions. An input clamping device can be used for input voltage limiting. An input fuse or an output fuse also be used to protect against over-loading.

- Dual outputs used as a single output

The +Vout and -Vout can be used to obtain a single output that is the sum of the two outputs. In this case, the COM pin shouldn't be used.

- External Regulator

An external 3-terminal regulator can be connected to the output of the converter to achieve full regulation. Make sure the converter's output voltage provides sufficient head room for the regulator. An additional benefit is that the built-in protection features in the regulator, such as OCP, OTP, etc, will protect the converter also. In a complimentary supply, a negative output regulator must be used to achieve the negative regulated output.

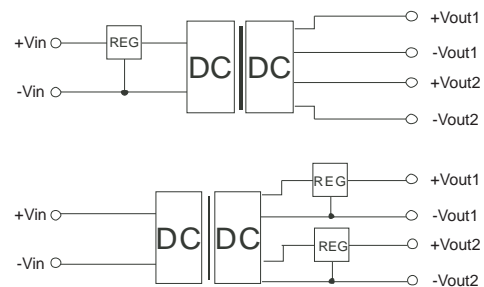

<Figure 2>